

Engine-powered Forklift Trucks 12000, 14000 and 16000 kg

Linde



H 120/1200
H 140/1200
H 160/600
H 160/1200

358

Introduction

The 12 to 16 tonne diesel counterbalanced trucks have been developed to suit a wide range of different applications and incorporate the latest technology in meeting the rigorous existing and anticipated environmental standards. The main design features result from a thorough analysis of materials handling requirements and will ensure maximum productivity. Operational efficiency is largely determined by the operator, the overall design concept was planned with the driver in mind.

The major characteristics at a glance

- Ergonomically optimised driver's compartment
- Powerful, modern diesel engine combining low fuel consumption with excellent exhaust emission characteristics fully satisfying the latest STAGE 2 standards
- Automatic three-speed transmission incorporating a reverse interlock, enabling safe, efficient working and providing high rates of acceleration and slowdown
- Engine speed-up design affording power-on-demand and anti-stall feature
- Robust drive axle with zero-maintenance wet disc brakes
- Heavy-duty steer axle
- Full capacity to 6.1 m

Driver's compartment with optimised ergonomics

Steps on either side of the vehicle provide access to the centralised driver's compartment. A comfortable suspension-type driver's seat is standard with full adjustment for weight and size of the operator. Operator controls satisfy the ergonomic standards defined by ISO 6682 and have all been further optimised for easy, effortless operation. A multifunction single hydraulic control lever provides all load control movements, facilitating smooth, easy load handling. Control and supervision instruments installed below the lower front cross member of the overhead guard. Major components constantly monitored, malfunctions are signalled through a central warning light – the driver is able to concentrate fully on the job in hand, in the safe knowledge that all important truck functions are subject to permanent, automatic supervision.

Stable, robust chassis

Monocoque fabricated steel plate chassis provides high strength to weight ratio and full protection to components. Sound deadening material on all inside surfaces. Full underbody covers, standard.

High-tech diesel engine

Perkins 6-cylinder diesel engine of 6 litres cubic capacity, equipped with turbocharger. Rated output 112 kW at 2500 rpm or 129.5 kW at 2500 rpm. This modern propulsion unit is notable for particularly smooth running with low noise emissions and outstandingly clean exhaust.

The automatic transmission and drive axle

Torque converter-coupled automatic three-speed powershift transmission. Reversing interlock. Speed-controlled downshift protection. For accurate lower-speed handling and positioning, the brake plate pressure switch is coupled to the accelerator pedal to enable transmission disconnect whilst maintaining high engine speed for hydraulic operations. Wide-track front drive axle incorporates two-stage reduction gearboxes. High-quality steel plate construction optimised for heavy-load handling.

Powerful brakes

Oil-actuated, hub-mounted wet disc brake units. Fail-safe oil actuated brake system. Input shaft, disc mounted hand brake unit. Foot brake application by applied pressure to the centralised brake plate. Parking brake application by electric switch situated on the operator's console.

Smooth power steering

Hydrostatic power steering allows full steering lock to be attained even at standstill. Accurate manoeuvrability with minimum effort. Line-mounted anti-shock valve. Cab-mounted anti-kick valve. Heavy-duty steer axle is mounted to the chassis via spherical bushes allowing axle articulation over uneven ground. Steering lock stops preventing cylinder overstroke.

LINDE

Forklift Truck

Data sheet for industrial trucks

Designation to VDI 3586

December 2003

				Linde	Linde	
Characteristics	1.1	Manufacturer		Linde	Linde	
	1.2	Model designation		H 120/1200	H 140/1200	
	1.3	Power unit: battery, diesel, petrol, LP gas, mains power		Diesel	Diesel	
	1.4	Operation: manual, pedestrian, stand-on, seated, order picker		Rider seated	Rider seated	
	1.5	Load capacity	Q (kg)	12000	14000	
	1.6	Load centre	c (mm)	1200	1200	
	1.8	Axle centre to fork face	x (mm)	930	975	
	1.9	Wheelbase	y (mm)	3670	3670	
	Weights	2.1	Service weight	kg	19597	21115
2.2		Axle load with load, front / rear	kg	29121 / 2440	31762 / 2953	
2.3		Axle load without load, front / rear	kg	10115 / 9482	10113 / 11002	
Wheels and tyres	3.1	Tyres front / rear: superelastic (SE), pneumatic (P)		P / P	P / P	
	3.2	Tyre size, front		12.00 x 20/20 PR	12.00 x 20/20 PR	
	3.3	Tyre size, rear		12.00 x 20/20 PR	12.00 x 20/20 PR	
	3.5	Wheels, number front / rear (x = driven)		4x / 2	4x / 2	
	3.6	Track width, front	b10 (mm)	1838	1838	
	3.7	Track width, rear	b11 (mm)	2067	2067	
Dimensions	4.1	Mast/fork carriage/truck tilt, forward / backward	deg.	5 / 10	5 / 10	
	4.2	Height of mast, lowered	h1 (mm)	3670 ¹⁾	3875 ¹⁾	
	4.3	Free lift	h2 (mm)	150	150	
	4.4	Lift	h3 (mm)	3700	3700	
	4.5	Height of mast, extended	h4 (mm)	5445	5650	
	4.7	Height of overhead guard (cabin)	h6 (mm)	3115	3115	
	4.8	Height, operator's seat / stand-on platform	h7 (mm)	1990	1990	
	4.12	Towing coupling height	h10 (mm)	550	550	
	4.19	Overall length	l1 (mm)	8000	8045	
	4.20	Length to fork face	l2 (mm)	5600	5645	
	4.21	Overall width	b1/b2 (mm)	2550	2550	
	4.22	Fork dimensions	s/e/l (mm)	90 x 180 x 2400 ³⁾	100 x 250 x 2400 ³⁾	
	4.23	Fork carriage		Pin type	Pin type	
	4.24	Width of fork carriage	b3 (mm)	2500	2500	
	4.25	Fork spread, min / max.	b5 (mm)	600 / 2250	770 / 2220	
	4.31	Ground clearance, mast	m1 (mm)	285 ¹⁾	250 ¹⁾	
		Ground clearance, carriage	m1 # (mm)	263 ¹⁾ ⁴⁾	280 ¹⁾ ⁴⁾	
	4.32	Ground clearance, centre of wheelbase	m2 (mm)	320	320	
	4.33	Aisle width with pallets 1000 x 1200 crosswise	Ast (mm)	-	-	
	4.34	Aisle width with pallets 800 x 1200 lengthwise	Ast (mm)	8685	8725	
4.35	Turning radius	Wa (mm)	5150	5150		
4.36	Minimum pivoting point distance	b13 (mm)	1475	1475		
Performance	5.1	Travel speed, with / without load	km/h	25 / 27	25 / 25	
	5.2	Lifting speed, with / without load	m/s	0.38 / 0.40	0.40 / 0.40	
	5.3	Lowering speed, with / without load	m/s	0.51 / 0.52	0.51 / 0.53	
	5.5	Tractive force, with / without load	kN	85 / -	100 / -	
	5.7	Climbing ability, with / without load	%	20 / -	23 / -	
	5.9	Acceleration time, with / without load	s	7.5 / 7.0	8.5 / 7.5	
	5.10	Service brake		Wet disc	Wet disc	
	6.4	Starting battery	V/Ah	24 V (2x 12/105)	24 V (2x 12/105)	
	Drive	7.1	Engine manufacturer /type		Perkins 1106C-E60TA	Perkins 1106C-E60TA
		7.2	Engine output to ISO 1585	kW	112 ²⁾	129.5 ²⁾
7.3		Rated speed	min ⁻¹	2500	2500	
7.4		Number of cylinders / displacement	cm ³	6 / 5980	6 / 5980	
7.5		Fuel consumption to VDI cycle	l/h	-	-	
Other	8.1	Type of drive control		Torque converter 3/3	Torque converter 3/3	
	8.2	Working pressure for attachments	bar	210	230	
	8.3	Oil flow for attachments	l/min	100	95	
	8.4	Noise level at operator's ear, overhead guard / cab	dB(A)	78	76	
	8.5	Trailer coupling, design / type, DIN	ø mm	50	50	
1) Mast lowered height with 150 mm free lift.					3) Optional hook-mounted forks available	
2) Optional 112kW engine for H 140, H 160/1200 or 129.5 kW engine for H 160/600, H 120/1200.					4) Pin-type fork carriage system – standard	

DFG

Registration note to VDI 3586

VDI 2198

Linde	Linde
H 160	H 160/1200
Diesel	Diesel
Rider seated	Rider seated
16000	16000
600	1200
930	975
3670	3670
19299	22597
32471 / 2899	35955 / 2647
9680 / 9620	10482 / 12115
P / P	P / P
12.00 x 20/20 PR	12.00 x 20/20 PR
12.00 x 20/20 PR	12.00 x 20/20 PR
4x / 2	4x / 2
1838	1838
2067	2067
5 / 10	5 / 10
3670 ¹⁾	3875 ¹⁾
150	150
3700	3700
5445	5650
3115	3115
1990	1990
550	550
6800	8045
5600	5645
2550	2550
90 x 180 x 1150 ³⁾	100 x 250 x 2400 ³⁾
Pin type	Pin type
2500	2500
600 / 2250	770 / 2220
285 ¹⁾	250 ¹⁾
263 ¹⁾ ⁴⁾	280 ¹⁾ ⁴⁾
320	320
7280	-
-	8725
5150	5150
1475	1475
25 / 27	24 / 26
0.38 / 0.40	0.40 / 0.40
0.51 / 0.52	0.51 / 0.53
85 / -	94 / -
20 / -	23 / -
7.5 / 7.0	8.5 / 7.5
Wet disc	Wet disc
24 V (2x 12/105)	24 V (2x 12/105)
Perkins 1106C-E60TA	Perkins 1106C-E60TA
112 ²⁾	129.5 ²⁾
2500	2500
6 / 5980	6 / 5980
-	-
Torque converter 3/3	Torque converter 3/3
250	250
100	95
78	76
50	50

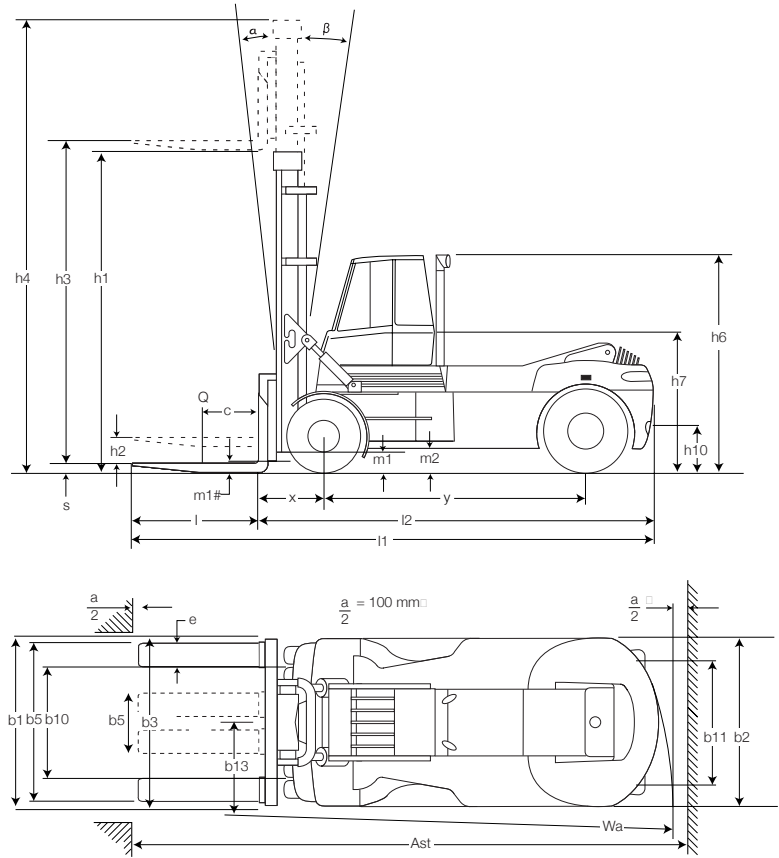

Lifting capacity diagrams:

H 120/1200

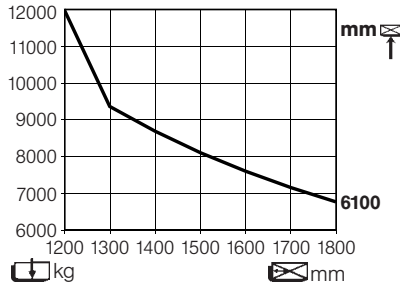

H 140/1200

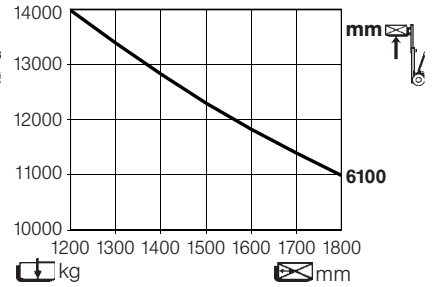

H 160

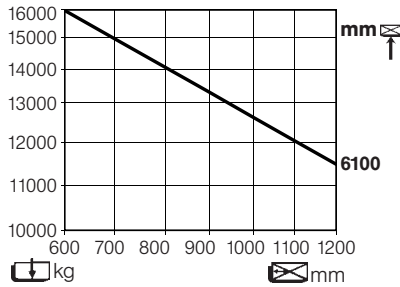

H 160/1200

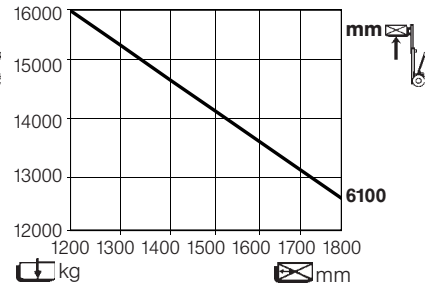

Standard Clearview Masts: H 160, H 120/1200

Lift	h ₃	3700	4300	4900	5500	6100	6700
Lift height	h ₂	150	150	150	150	150	150
Height, mast lowered	h ₁	3595	3895	4195	4495	4795	5095
Height, mast extended	h ₄	5445	6045	6645	7245	7845	8445

Standard Clearview Masts: H 140/1200, H 160/1200

Lift	h ₃	3700	4300	4900	5500	6100
Lift height	h ₂	150	150	150	150	150
Height, mast lowered	h ₁	3800	4100	4400	4700	5000
Height, mast extended	h ₄	5650	6250	6850	7450	8050

le - pin-mounted type standard.

ard.

Equipment



Lift mast

Robust clearview fabricated mast of all-roller construction affording great strength, maximum load stability and mast rigidity at full lift height. Full-width load rollers and side thrust rollers between inner and outer mast ensure complete alignment. Pin-type carriage plate is standard and is roller-mounted into the mast. Fork carrier, pin-mounted to the carriage plate provides rapid interchange for forks and attachments.

Safety

- Transmission – integrated forward/reverse interlock and downshift protection
- Engine – neutral start transmission safety interlock
- Safe load lowering valve
- Steering control – integrated anti-kick valve
- Steering axle proximity mounted shock valve
- High-mounted cab – excellent all-round visibility
- Low noise emissions
- Central warning lamp (instrument monitoring)
- Horn

Standard equipment

- Fully equipped cab with hinged doors, sliding window left side, wipers and washers for windscreen, rear screen and overhead guard screen, heater and demister
- Fully adjustable suspension-type seat
- Comprehensive instrumentation
- Perkins diesel engine with turbocharger
- Clark 3-speed powershift transmission with integrated forward/reverse safety interlock; automatic transmission ratio selection
- Heavy-duty double hub reduction drive axle, incorporating oil bath-type multi-disc brakes with zero maintenance requirements
- Anti-stall engine speed-up device for all working hydraulic functions
- Power-assisted hydraulic steering
- Twin-mounted drive wheels
- Pneumatic tyres
- Standard clearview lift mast, 3700 mm lift
- Pin-type non-hydraulic fork carriage
- Forks 2400 mm long (1150 mm, H 160)
- Safety monitors for engine, oil and water temperature
- Standard colour scheme – vermilion and charcoal grey

Optional equipment

- 129.5 kW or 112 kW power units
- Standard clearview masts (see mast tables for details)
- Full free-lift duplex lift masts
- Full free-lift triple lift masts
- Hydraulic fork carriage
- Hook-type forks
- Sideshift carriage
- Carriage backrest extension
- Alternative fork lengths and fork extensions
- Crane jib
- Coil boom
- Paper roll clamps
- Load weight indicator
- Particle filter
- High-level engine pre-filter
- Spark arrestor
- Exhaust purifier
- Cold climate specification to -25°C
- Cabin pre-heat system
- Climate control
- High-level heater intake
- Road lighting
- Working lights
- Radio/cassette player
- Adjustable steering column
- Alternative colour schemes